

1" APPLIX #800 LOOP SEWN TO VINYL (4) EDGES.

GENERAL NOTES:

1. A18-11-7005, BURGUNDY; A18-11-7007, POTOMAC BLUE; A18-11-7002, CHESAPEAKE SAND: NEW ASSEMBLY P/N'S.
2. V18-11-7005, BURGUNDY; V18-11-7007, POTOMAC BLUE; V18-11-7002, CHESAPEAKE SAND: VENDOR REWORK P/N'S.
3. SAMPLES WILL BE PROVIDED FOR PRODUCTION PURPOSES.
4. FOAM BONDED TO PAN WITH K-GRIP 200 CONTACT ADHESIVE.
5. DEBURR AND REMOVE ALL SHARP EDGES AND CORNERS.
6. DIMENSION UNITS ARE INCHES [MILLIMETERS].

ASSEMBLY, SEAT BACK, 39" (00)

CONTROLLED

Item No.	QTY	P/N	Description	Material/Spec	Weight/Dimensions
08	1		LABEL, (DESCRIPTION, MFG, P/N)	PAINTED STENCIL OR INDELIBLE INK LABEL	>1.5" x 6"
07	1		APPLIX, 1"x7", #800 HOOK, PAIHO R1001H-25 OR EQUAL	POLYAMIDE	
06	1		APPLIX, 2"x7.5", #800 HOOK, PAIHO R2001H-25 OR EQUAL	POLYAMIDE	
05	2		APPLIX, 2"x15", #800 HOOK, PAIHO R2001H-25 OR EQUAL	POLYAMIDE	
04	1		APPLIX, 2"x17", #800 HOOK, PAIHO R2001H-25 OR EQUAL	POLYAMIDE	
03	1	020-CP0278	UPHOLSTERY, COVER, BACK, 39"	OMNOVA PREVAIL W/PREFFX SEE SHEET 4	
02	1	020-CP0100	FOAM, BACK CUSHION, 39"	FOAM, CHESTNUT RIDGE SAFEGUARD XL, MEDIUM DENSITY NEOPRENE	
01	1	020-CP0160	PAN, BACK CUSHION, 39"	LOW CARBON STEEL, COMMERCIAL QUALITY QUALITY IN ACCORDANCE W/ASTM A-366	.04 THK
00	1		ASSEMBLY, SEAT BACK, 39"		

D	PAGE 20F4, DIMENSION 10.50 WAS 11.50. 02AUG12 ALC	UNLESS OTHERWISE SPECIFIED FRACTIONS ±1/16" DECIMALS .X	Drawn by: A.CREECH	Int. Date: 11MAY11	IF THIS DOCUMENT IS NOT MARKED "CONTROLLED" IN RED, THEN IT SHOULD BE USED AS REFERENCE ONLY.	WASHINGTON METROPOLITAN AREA TRANSIT AUTHORITY Title: 1K - 6K SERIES ASSEMBLY, SEAT BACK, 39" CAR BODY
			Engr. Approval:	Int. Date:		
C	PAGE 10F4, REVISED BOM AND GENERAL NOTES. PAGE 40F4, REVISED/ADDED MAT'L ID P/N. 21MAR12 ALC	.XX±.03 [.76] .XXX±.01 [.25]	Approved by:	Int. Date:	THE DESIGN, CONCEPT AND INFORMATION CONTAINED IN THIS DRAWING IS PROPRIETARY TO WASHINGTON METROPOLITAN AREA TRANSIT AUTHORITY AND MAY NOT BE REPRODUCED, USED OR DISCLOSED WITHOUT WRITTEN PERMISSION OF SAID COMPANY.	Part. No.: A18-11-7005
B	REMOVED REFERENCE TO WMATA SPECIFICATIONS, CHAPTER 10.0, PAGE 4. 06FEB12 ALC	ANGLES ±1° UPHOLSTERY ±.25 [6.35]	Undim. Edges:	Scale: NOT TO SCALE	Sheet Size: B	Dwg. No.: WDA18117005-D
A	REVISED UPHOLSTERY COVERS AS PER VENDOR PROVIDED DATA. 05JAN12 ALC	Undim. Wall Thk.: Undim. Radii:	Undim. Edges:	Scale:	Sheet Size:	Sheet: 1 of 4
-	INITIAL RELEASE 11MAY11 ALC					

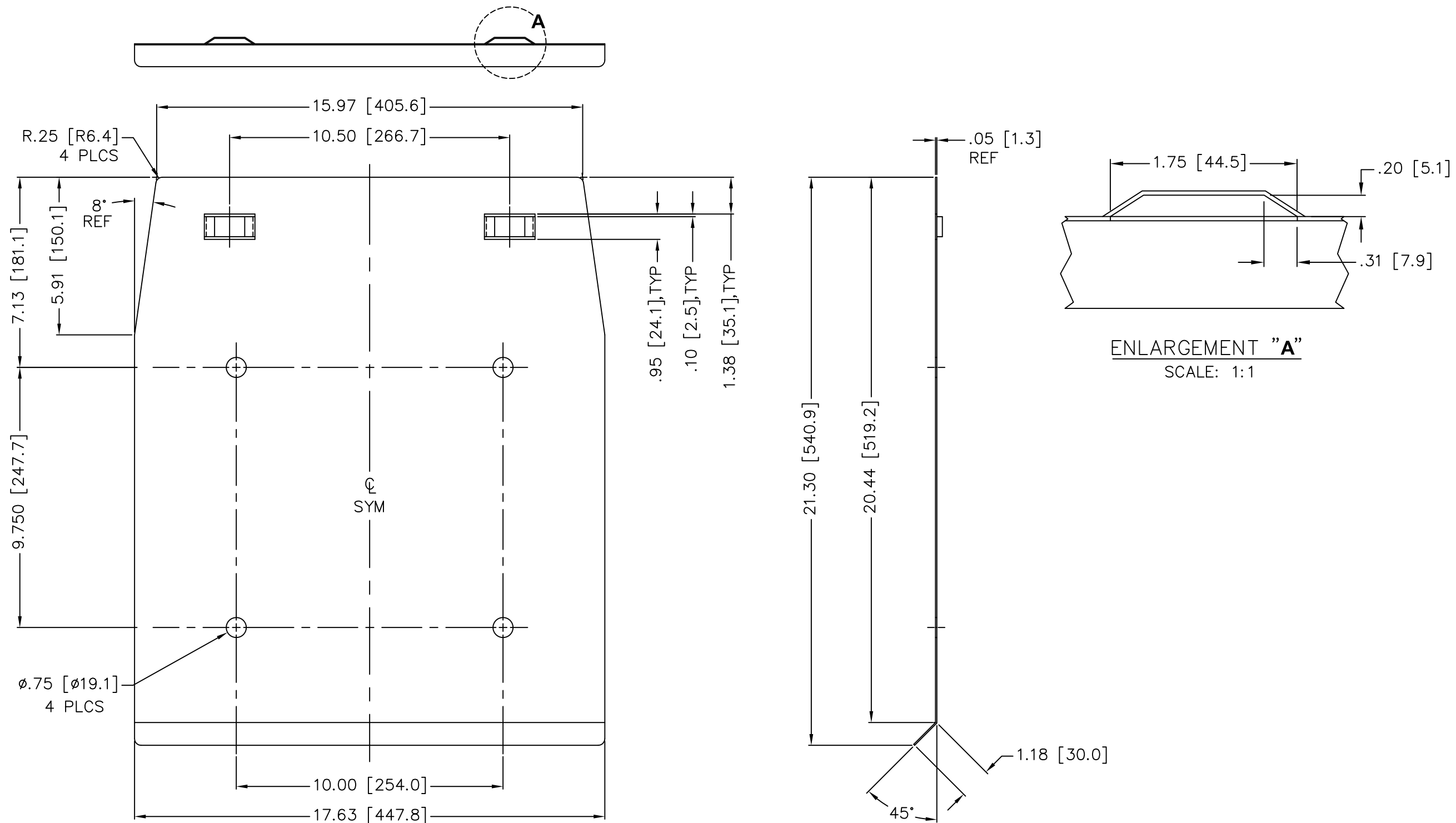

PAN, BACK CUSHION, 39" (01)
 PART IS SYMETRICAL ABOUT CENTERLINE
 SCALE: 1:0.25

CONTROLLED

GENERAL NOTES:

1. PAINT: SEE APPROVED PRODUCTS SHEET 4 OF 4.
2. DEBURR AND REMOVE ALL SHARP EDGES AND CORNERS.
3. SAMPLES WILL BE PROVIDED FOR PRODUCTION PURPOSES.

D	PAGE 2 OF 4, DIMENSION 10.50 WAS 11.50. 02AUG12 ALC	UNLESS OTHERWISE SPECIFIED FRACTIONS ±1/16" DECIMALS .X	Drawn by: A.CREECH	Int. Date: 11MAY11	IF THIS DOCUMENT IS NOT MARKED "CONTROLLED" IN RED, THEN IT SHOULD BE USED AS REFERENCE ONLY.	WASHINGTON METROPOLITAN AREA TRANSIT AUTHORITY
	C		PAGE 1 OF 4, REVISED BOM AND GENERAL NOTES. PAGE 4 OF 4, REVISED/ADDED MAT'L ID P/N. 21MAR12 ALC	Engr. Approval:		
B	REMOVED REFERENCE TO WMATA SPECIFICATIONS, CHAPTER 10.0, PAGE 4. 06FEB12 ALC	.XX±.03 [.76] .XXX±.01 [.25]	Approved by:	Int. Date:	<small>THE DESIGN, CONCEPT AND INFORMATION CONTAINED IN THIS DRAWING IS PROPRIETARY TO WASHINGTON METROPOLITAN AREA TRANSIT AUTHORITY AND MAY NOT BE REPRODUCED, USED OR DISCLOSED WITHOUT WRITTEN PERMISSION OF SAID COMPANY.</small>	Title: 1K - 6K SERIES PAN, BACK CUSHION, 39" CAR BODY
A	REVISED UPHOLSTERY COVERS AS PER VENDOR PROVIDED DATA. 05JAN12 ALC	ANGLES ±1° UPHOLSTERY ±.25 [6.35]	Undim. Edges:	Scale: 1:0.25		
Rev.	Description & Date	Undim. Wall Thk.: Undim. Radii:	Undim. Edges:	Scale:	Next Assembly:	Dwg. No.: WDA18117005-D

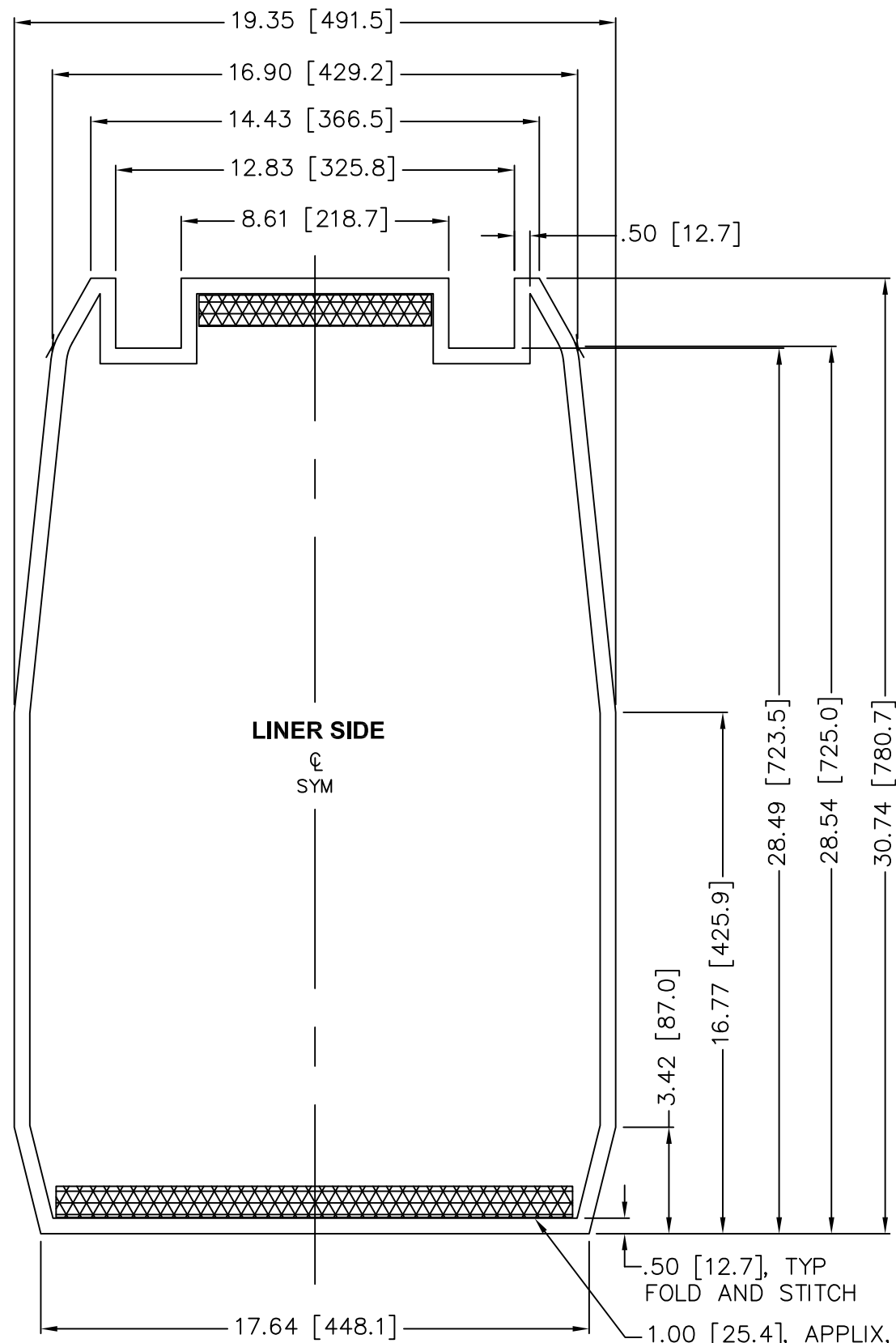

LINER SIDE
 ⊕
 SYM

UPHOLSTERY, COVER, BACK, 39" **03**
 MATERIAL IS SYMMETRICAL ABOUT CENTERLINE

GENERAL NOTES:

- SAMPLES WILL BE PROVIDED FOR PRODUCTION PURPOSES.

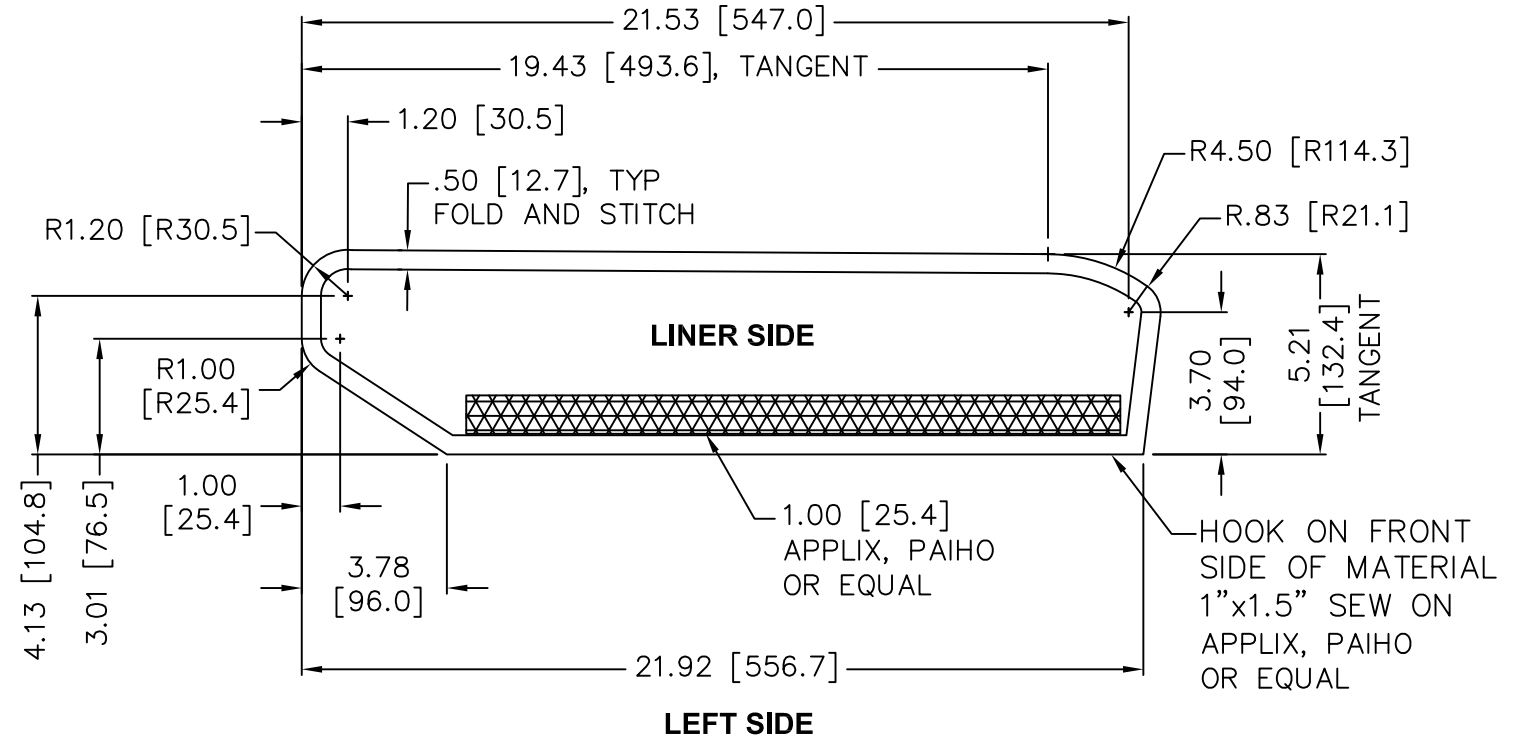

LINER SIDE

LEFT SIDE

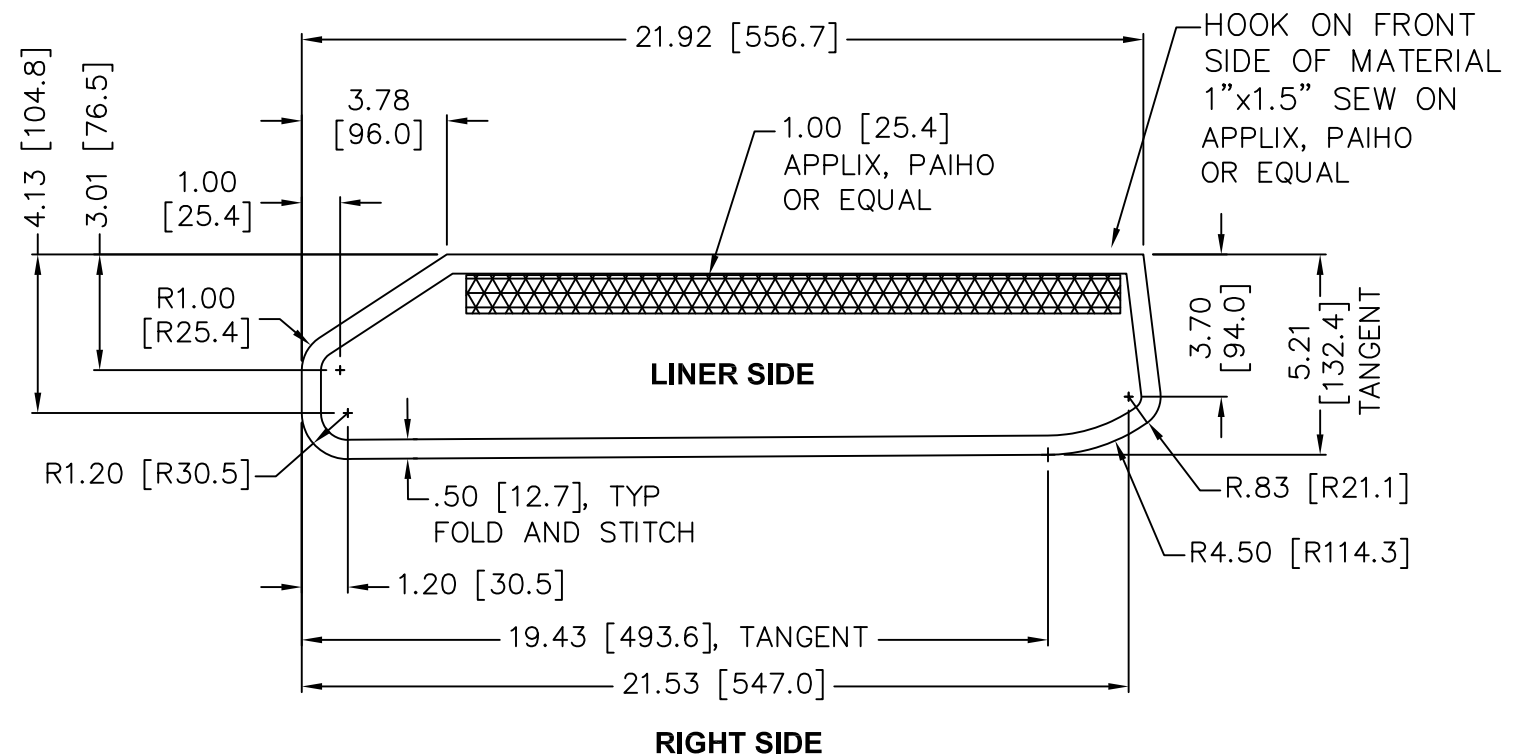

LINER SIDE

RIGHT SIDE

CONTROLLED

D	PAGE 20F4, DIMENSION 10.50 WAS 11.50. 02AUG12 ALC	UNLESS OTHERWISE SPECIFIED FRACTIONS ±1/16" DECIMALS .X .XX±.03 [.76] .XXX±.01 [.25] ANGLES ±1° UPHOLSTERY ±.25 [6.35]	Drawn by: Int. Date:	IF THIS DOCUMENT IS NOT MARKED "CONTROLLED" IN RED, THEN IT SHOULD BE USED AS REFERENCE ONLY.	M WASHINGTON METROPOLITAN AREA TRANSIT AUTHORITY	
	C		PAGE 10F4, REVISED BOM AND GENERAL NOTES. PAGE 40F4, REVISED/ADDED MAT'L ID P/N. 21MAR12 ALC			A.CREECH <i>ALC</i> 11MAY11
	B		REMOVED REFERENCE TO WMATA SPECIFICATIONS, CHAPTER 10.0, PAGE 4. 06FEB12 ALC			Engr. Approval: Int. Date:
	A		REVISED UPHOLSTERY COVERS AS PER VENDOR PROVIDED DATA. 05JAN12 ALC			Approved by: Int. Date:
Rev.	INITIAL RELEASE 11MAY11 ALC	Undim. Wall Thk.: Undim. Radii:	Undim. Edges: Scale: 1:0.2	Sheet Size: Next Assembly: B	Title: 1K - 6K SERIES UPHOLSTERY, COVER, BACK, 39" CAR BODY	
	Description & Date				Part. No.: A18-11-7005	
					Dwg. No.: WDA18117005-D	
					Sheet: 3 of 4	

PHYSICAL PROPERTIES, FOAM

TENSILE STRENGTH:
 5.0 lbf/in² MINIMUM WHEN TEST TO ASTM D-3574 TEST E.
 ELONGATION:
 70% MINIMUM WHEN TESTED TO ASTM D-3574 TEST E.
 COMPRESSION:
 SET AT 50%, 15% MAXIMUM WHEN TESTED ACCORDING TO ASTM D-1055.
 FLEX FATIGUE:
 THICKNESS LOSS 5% MAXIMUM WHEN TESTED ACCORDING TO ASTM D-1055.
 TEAR STRENGTH:
 2.0 lbf/in² MINIMUM WHEN TESTED TO ASTM D-3574.
 INDENTATION FORCE DEFLECTION (IFD):
 INTERIOR SEAT BACK IFD 32±8 lbf
 INTERIOR SEAT BOTTOM IFD 42±8 lbf
 DYNAMIC FATIGUE CONSTANT FORCE POUNDING:
 35 MAXIMUM WHEN TESTED ACCORDING TO ASTM D-3574-95 TEST 13 80,000 CYCLES,
 IFD LOSS AT .40% DEFLECTION.
 RESILIENCY:
 25% MINIMUM WHEN TESTED ACCORDING TO ASTM D-3574-95, TEST H

SMOKE, FLAME AND TOXICITY REQUIREMENTS

ASTM D-3675 I <25
 ASTM E-662 Ds (1.5) <100
 ASTM E-662 Ds (4.0) <175
 TOXICITY:
 BOMBARDIER SMP 800-C.

SEAT COVER CHARACTERISTICS

STITCHING

HIGH QUALITY BONDED NYLON THREAD, LEFT TWIST, LUBED, COLORFAST OR EQUIVALENT. FIVE (5) THREADS PER INCH. BACKSTITCH >1/2" FROM SEAM ENDS INCLUDING VELCRO STITCHING.

UPHOLSTERY

THE SEAT UPHOLSTERY MATERIAL SHALL BE MADE OF INDUSTRIAL GRADE FABRIC-BACKED VINYL WHICH IS SUITABLE FOR USE IN THE TRANSIT ENVIRONMENT, MINIMUM WITH A WEIGHT OF 24 OUNCES PER SQUARE YARD.

SEAT COVER CHARACTERISTICS – CONTINUED

THE MATERIAL SHALL BE CAPABLE OF PASSING ALL OF THE FOLLOWING PHYSICAL TESTS FOR TEXTILE PRODUCT.

TEST METHOD	DESCRIPTION	CRITERIA
AATCC-1 6A	COLORFASTNESS-200 HRS	CLASS 5 (NO CHANGE)
ASTM D-751	WEIGHT	24 oz./sq.yd. (MIN.)
ASTM D-751	TENSILE STRENGTH (GRAB)	120 MD*x110 CMD** (POUNDS)
ASTM D-751	SEAM STRENGTH	95 MD*x85 CMD** (POUNDS)
ASTM D-751	TEAR STRENGTH (TONGUE)	8 MD*x8 CMD** (POUNDS)
ASTM D-751	ADHESION OF COATING (lb./2in)	6 MD*x6 CMD** (POUNDS)
ASTM D-751	BLOCKING	SCALE RATING NO. 2 MAX. (175°F-30min.)
ASTM D-1308	STAIN RESISTANCE	SCALE RATING NO. 4 MIN.
ASTM D-2097	FLEXING (30,000 CYCLES)	NO CRACKING OR FLAKING
ASTM D-4157-92	ABRASION (500,000 CYCLES)	NO WEAR THROUGH (#8 COTTON DUCK ABRADANT)
ASTM D-5733	TEAR STRENGTH (TRAPEZOID)	30 MD*x30 CDM** (POUNDS)
ASTM E-662	SMOKE GENERATION	Ds (4.0), <=/=200 (COATED), Ds (4.0) <=/=125 (UNCOATED)
FAR 25.853b	FIRE TEST	SE<10 sec. NO FLAMING DRIPPING
CFFA-6a	COLD CRACK	-20°F MIN.
TOXICITY	BOMBARDIER	SMP 800-C

MD* – DESIGNATES MACHINE DIRECTION
 CMD** – DESIGNATES CROSS MACHINE DIRECTION
 NOTE: THE STITCH SHALL BE LOCK TYPE IN ACCORDANCE WITH FEDERAL SPECIFICATIONS 30.1

MATERIAL IDENTIFICATION - SEAT BACK, 39"

	WMATA P/N	THREAD COLOR
BURGUNDY T508 SADDLE.....	A18-11-7005, B18-11-5717, L18-11-3081.....	WINE E NYLON TYPE 2 CLASS A VT295E 787Q
	M18-11-0663, M18-11-3119, M18-11-5717, M18-11-6007, V18-11-7005	
POTOMAC BLUE T509 SADDLE.....	A18-11-7007, B18-11-5716, L18-11-3080.....	YALE BLUE E NYLON TYPE 2 CLASS A VT295E 764Q
	M18-11-0662, M18-11-3120, M18-11-5716, M18-11-6006, V18-11-7007	
CHESAPEAKE SAND T510 SADDLE.....	A18-11-7002, B18-11-5718, L18-11-3082.....	BEIGE E NYLON TYPE 2 CLASS A VT 295E 751Q
	M18-11-0664, M18-11-3118, M18-11-5718, M18-11-6005, V18-11-7002	

APPROVED PRODUCTS

VINYL – OMNOVA SOLUTIONS, INC.
 FOAM – CHESTNUT RIDGE FOAM, INC
 PAINT – **NEW** –POWDER COAT ANSI GRAY (PAS6-C001)
REPAIR –POLYURETHANE SHERWIN-WILLIAMS POLANE,
 ANSI GRAY OR EQUAL. SAND PRIOR TO PAINT.
 HOOK-AND-LOOP FASTENER – APPLIX #800 OR PAIHO TRIHOOK

CONTROLLED

D	PAGE 2 OF 4, DIMENSION 10.50 WAS 11.50. 02AUG12 ALC	UNLESS OTHERWISE SPECIFIED FRACTIONS ±1/16" DECIMALS .X .XX±.03 [.76] .XXX±.01 [.25]	Drawn by: Int. Date: A.CREECH <i>ACC</i> 11MAY11	IF THIS DOCUMENT IS NOT MARKED "CONTROLLED" IN RED, THEN IT SHOULD BE USED AS REFERENCE ONLY.	 WASHINGTON METROPOLITAN AREA TRANSIT AUTHORITY
	C		Engr. Approval: Int. Date:		
B	PAGE 1 OF 4, REVISED BOM AND GENERAL NOTES. PAGE 4 OF 4, REVISED/ADDED MAT'L ID P/N. 21MAR12 ALC	ANGLES ±1°	Approved by: Int. Date:	THE DESIGN, CONCEPT AND INFORMATION CONTAINED IN THIS DRAWING IS PROPRIETARY TO WASHINGTON METROPOLITAN AREA TRANSIT AUTHORITY AND MAY NOT BE REPRODUCED, USED OR DISCLOSED WITHOUT WRITTEN PERMISSION OF SAID COMPANY.	Title: 1K – 6K SERIES TECHNICAL SPECIFICATIONS CAR BODY
A	REMOVED REFERENCE TO WMATA SPECIFICATIONS, CHAPTER 10.0, PAGE 4 06FEB12 ALC	UPHOLSTERY ±.25 [6.35]	Undim. Edges: Scale: N/A	Sheet Size: Next Assembly: B	Part. No.: A18-11-7005
Rev.	INITIAL RELEASE 11MAY11 ALC	Undim. Wall Thk.: Undim. Radii:			Dwg. No.: WDA18117005-D Sheet: 4 of 4